

The Truflo MF1000 Series Flanged Magnetic Flow Meters provide long-lasting, reliable performance in even the most challenging applications. The MF1000 is a microprocessor-based flow transmitter that has been engineered for high performance, easy installation, commissioning and maintenance. The transmitter is truly robust, cost-effective and suitable for all-round applications and has a measuring accuracy of $\pm 0.5\%$ of the flow rate. The all-welded construction provides a hermetic seal that protects against moisture and other contaminants. The sealed housing ensures maximum sensor reliability by protecting all internal components and wiring from even the most aggressive environments.



Measuring principle

The Truflo MF1000 Series Electromagnetic Flow Meter consists of sensor & converter. The measuring tube is equipped magnet exciting coil. The converter provide current to magnet exciting coil and generate magnetic field which filled measuring tube, one or more pairs of electrode which are fixed in inner-wall of the measuring tube (verticale to field direction) detect and lead to induced electromotive force after contact liquid, then delivery to converter through cable and do signal processing. Insulation lining is fixed in inner-wall of the measuring tube, and make the measuring tube high resistant and nonmagnetic. Lining contacts with the measuring fluid, different causticity, abrasiveness and temperature of fluid choose different types of lining.

SPECIFICATIONS

Standard of execution	Electromagnetic flow meter
Nominal path (mm) (Customizable)	Pipe type PTFE lining Tubular chloroprene rubber lining
Flow direction	Positive, negative, net flow
Range ratio	20 : 1
Repeatability	$\pm 0.1\%$
Accuracy	$\pm 0.5\% \pm 1.0\%$
Temperature	Conventional rubber lining : -20 - +60°C High-temp rubber lining : -20 - +90°C PTFE lining : -30 - +120°C High-temp PTFE lining : -20 - +160°C
Working pressure	1/2" ~ 2" 4.0MPa 3" ~ 12" 1.6MPa 14" ~ 24" 1.0MPa
Velocity range	0.5 - 10m/s
Signal output	4 - 20mA Frequency Pulse RS 485
Communication output	RS48S, MODBUS, HART, Profibus-DP
Power supply	220VAC $\pm 15\%$, 24VDC, Battery
Length of straight pipe	Upper reaches .. SDN, Lower reaches .. 2DN
Relative humidity	5% - 95%
IP grade	IP65 - IP68
Ambient temperature	-25 - 60°C

FEATURES

- Heavy Duty Industrial Design
- Full Port
- High Accuracy
- Excellent Chemical Resistance
- Excellent Abrasion Resistance
- User Friendly Programming
- 4 - 20mA current, Frequency Pulse, 485 communication

Installation size

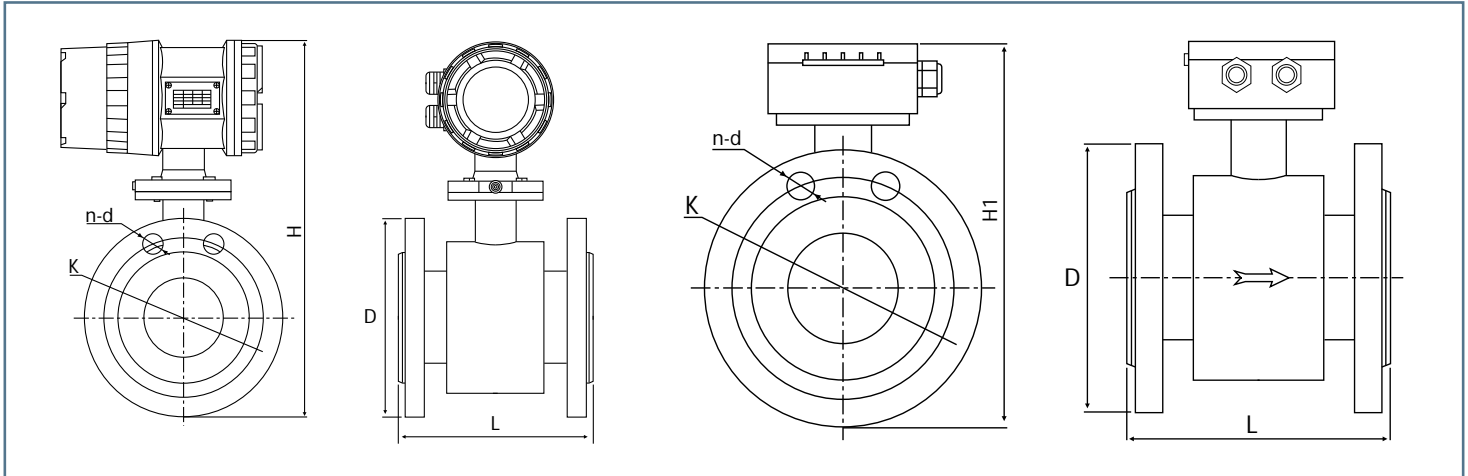

Dimensions

Size		L	D	K	H	H ₁
DN	In	(mm)	(mm)	(mm)	(mm)	(mm)
15	½"	200	95	65	199	242
20	¾"	200	105	75	304	247
25	1.0"	200	115	85	312	255
40	1 ½"	200	150	110	340	283
50	2"	200	165	125	353	296
80	3"	200	200	160	375	328
100	4"	250	220	180	404	375
150	6"	300	285	240	461	404
200	8"	350	340	295	517	460

Flow Rates

Speed (m/s)		0.3	0.4	0.5	1	2	3	4	5	6	7	8	9	10
Flow(m³/h)														
Size (mm)	In													
15	½"	0.2	0.3	0.4	0.6	1.3	1.9	2.5	3.2	3.8	4.5	5.1	5.7	6
20	¾"	0.4	0.5	0.6	1.1	2.3	3.4	4.5	5.7	6.8	7.9	9	10	15
25	1.0"	0.6	0.7	0.9	1.8	2.5	5.3	7.1	8.8	11	12	14	16	20
40	1 ½"	1.4	1.8	2.5	4.5	9	14	18	23	27	32	36	41	45
50	2"	2.2	2.8	3.5	7.1	14	21	28	35	42	49	57	64	70
80	3"	5.4	7.2	9	18	36	54	72	90	100	120	140	160	110
100	4"	8.4	11	14	28	57	85	110	140	170	190	220	250	280
150	6"	20	25	32	64	120	190	250	310	380	440	500	570	630
125	8"	34	45	57	110	220	340	450	560	670	790	900	1000	1100

