

TIB SERIES

Battery Operated Flow Meter

Operating Manual



Table of Contents

Safety Information 03

New ShearPro® Design 04

Zirconium Ceramic Rotor | Bushings 04

Technical Specifications 04

Long Service Life 05

Pressure vs. Temperature 05

Display Functions 05

Programming 06

Programming Display Units 06

Min | Max Flow Rates 07

K - Factors 07

Installation Information 08

Sensor Installation 08

Correction Sensor Position 09

Battery Replacement V Series 10

Battery Replacement H Series 11

Rotor Pin | Paddle Replacement 12

Dimensions 13

Warranty, Returns and Limitations 14



Corrosion-Free
Instrumentation Equipment

Safety Information

1. De-pressurize and Vent System Prior to Installation or Removal.
2. Confirm Chemical Compatibility Before Use.
3. DO NOT exceed Maximum Temperature or Pressure Specifications.
4. ALWAYS Wear Safety Goggles or Face-shield During Installation and/or Service.
5. DO NOT Alter Product Construction.



Warning | Caution | Danger

Indicates a potential hazard. Failure to follow all warnings may lead to equipment damage, injury, or death



Hand Tighten Only

Overtightening may permanently damage product threads and lead to failure of the retaining nut.



Note | Technical Notes

Highlights additional information or detailed procedure.



Do Not Use Tools

Use of tool(s) may damage product beyond repair and potentially void product warranty.



WARNING!



Do Not Remove Under Pressure

Failure to follow these instructions may result in the sensor being ejected from the pipe!

If leaking is observed from the retaining cap, it indicates defective or worn o-rings on the sensor. Do not attempt to correct by further tightening.

Gauges are not to be subject to water hammer or pressure spikes!

Before installation be certain the appropriate gauge has been selected considering operating pressure / full scale pressure / proof pressure, wetted material requirements, media compatibility, operating temperature, vibration, pulsation, desired accuracy and any other gauge component related to the service application (including the potential need for protective attachments and/or special installation requirements). Failure to do so could result in equipment damage, gauge failure and / or personal injury. Only qualified personnel should be permitted to install and maintain pressure gauges

Installation Safety Information



When installing the gauge connection into the application, use the wrench area to thread in and tighten the gauge. Do not use the gauge case to install the gauge.

This could result in loss of accuracy, excessive friction, or mechanical damage to the pressure element or gauge case. The gauge connection must be compatible with the mating connection and must be assembled appropriately. If the mating parts do not seal completely, a sealing material may be considered.

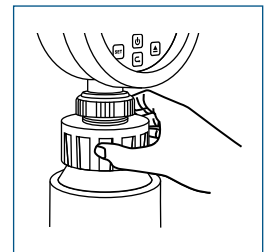

Pressurize System Warning

Sensor may be under pressure, take caution to vent system prior to installation or removal. Failure to do so may result in equipment damage and/or serious injury

Personal Protective Equipmet (PPE)

Always utilize the most appropriate PPE during installation and service of Truflo products.

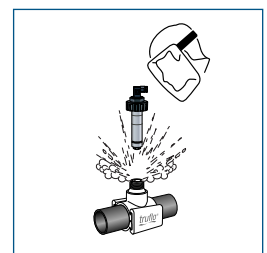

New ShearPro® Design

- ❑ Superhydrophobic Design
- ❑ Contoured Flow Profile
- ❑ Reduced Turbulence
- ❑ Reduced Friction
- ❑ 78% Less Drag than Old Flat Paddle Design*

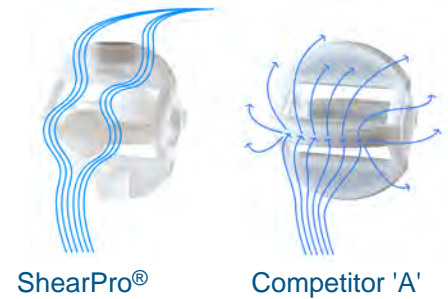

Zirconium Ceramic Rotor | Bushings

- ❑ Industry's Highest Impact and Chemical Resistant Properties
- ❑ Up to 15x the Wear Resistance vs. Regular Ceramic
- ❑ Nano-Polished Mirror Finished vs. Regular Ceramic - Less Friction
- ❑ Integral Rotor Bushings, Reduce Wear & Fatigue Stress



*Ref: NASA "Shape Effects on Drag" **

Technical Specifications

Operating Voltage	<1.5 mA @ 3.3 to 6 VDC
Battery	Lithium Battery
Life of Battery	> 7 Years
Current Consumption	60mA max.
Flow Rate GPM LPM	0.0 ~ 999.9
Fluid	H ₂ O or Liquid Chemicals
Accuracy	± 0.5% of F.S. @ 25°C
Response Frequency	5K Hz
Max Flow Rate	10m/s 33ft/s
Min Flow Rate	0.1m/s 0.3ft/s
Material of Construction	Paddle Tefzel® Rotor Bushings Zirconium Ceramic Sensor Body PVC PP PVDF
O-Ring Material	Viton (std) EPDM*
Operating Temperature	PVC < 60°C PP < 80°C PF < 100°C
Protection Class	IP-65 General Purpose
Approval	CE RoHS

*Optional

Long Service Life

The TIB Series is equipped with a Zirconium Ceramic Rotor Pin and 2 Bushings. The TIB Series also incorporates a contoured, 'Low Drag' Paddle Wheel leading to reduced drag, longer wear and a higher accuracy.

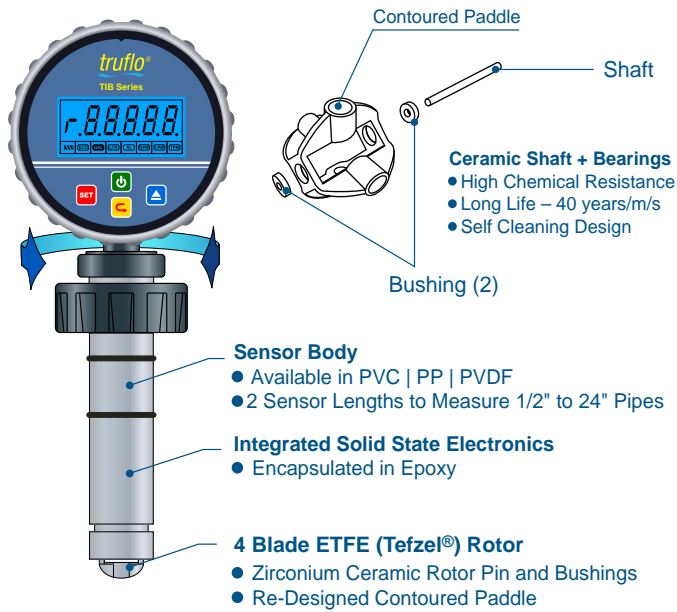

Pressure vs. Temperature

Note : During system design the specifications of all components must be considered. | Non-Shock

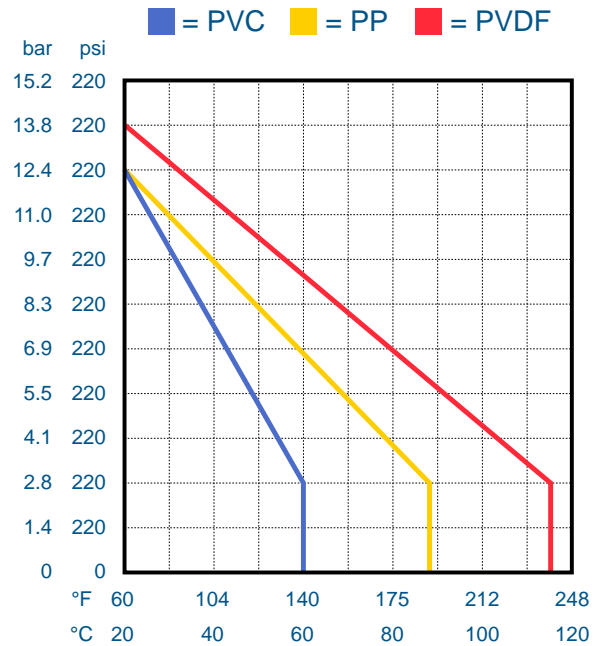

Display Functions

r indicates Flow Rate Mode

3 secs to Change from Flow Rate to Flow Total

3 Secs to view 6 Digits while in Totalizer Screen

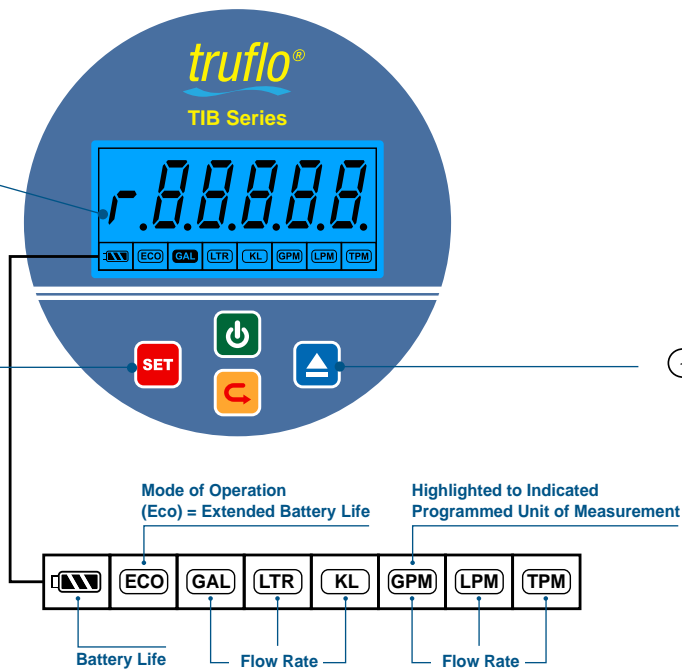

Programming

Press to Increase Value	Press to Decrease Value
Press to Save Value	Press to Change Value

STEPS	DISPLAY	RANGE	OPERATION
Step-1 Home Screen Press & (HOLD) 3 sec		Display Flashing	Current Flow Rate Total
Step-2 Screen Lock Press Key		0-1	Programming Lock Out Feature LCK= '0' Unlocked : Factory Default LCK= '1' Locked
Step-3 K Factor Press Key		0.1-9999	Enter K Factor Value See Chart on Page 7 for K-Factor Value
Step-4 Display Mode Press Key		non Eco	dSP.non - LED back light Default is set to 5 seconds dSP-Eco - Back Light Function is not Active Extended Battery Life
Step-5 Light - On Press Key		1-9999	Time on for Back Light Secs *Longer Time = Shorter Battery Life
Step-6 Flow Alarm Delay Press Key		1-9999	Time Delay for Visual Alarm
Step-7 Reset Totalizer Press Key		Programming Totalizer Password	rESEt.0 - Flow Totalizer Reset Disabled rESEt.1 } Default) - Flow Totalizer Reset Enabled

Programming Display Units

STEPS	DISPLAY	SELECTION	OPERATION
Step-1 Display Units Press (HOLD) 3 sec		Display Units Flow Rate/ Total	Press to Select & Press To Confirm 1. Flow Rate - GPM LPM TPM 2. Flow Total - GAL LTR KL

1. Totalizer Reset → Press Both Together for 3 Seconds



2. Sleep Mode → Press for 3 Seconds to Reduce Power Consumption



3. Alarm Setup → Press Both Together for 3 Seconds



Min | Max Flow Rates

Pipe Size	Flow Rate (LPM) / USGPM	
	0.3m/s min.	10m/s max.
2" DN50	40.0 10.5	357.0 1350.0
2 ½" DN60	60.0 16.0	1850 357
3" DN80	90.0 24.0	2800 739
4" DN100	125.0 33.0	4350 1149
6" DN150	230.0 60.0	7590 1997
8" DN200	315.0 80.0	10395 2735

K- Factors

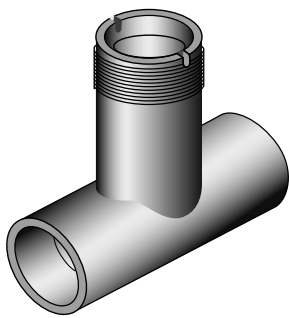
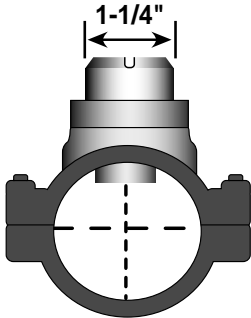
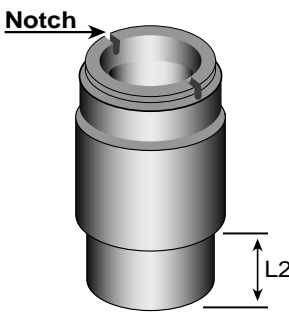
TEE FITTINGS					CLAMP SADDLES					CPVC SOCKET WELD-ON ADAPTERS				
														
Tee Fitting (Unit:inch)			K-Factor	Sensor Length	Tee Fitting (Unit:inch)			K-Factor	Sensor Length	Tee Fitting (Unit:inch)			K-Factor	Sensor Length
Size	DN	Id	CPVC SCH80		Size	DN	Id	CPVC SCH80		Size	DN	Id	CPVC SCH80	
½"	15	0.55	1013.04	S	2"	50	1.9	81.65	S	2"	50	1.9	81.65	S
¾"	20	0.74	604.80	S	2-½"	65	2.3	54.43	S	2-½"	65	2.3	54.43	S
1"	25	0.96	408.24	S	3"	80	2.9	34.96	S	3"	80	2.9	34.96	S
1-¼"	32	1.30	250.40	S	4"	100	3.8	19.80	S	4"	100	3.8	19.80	S
1-½"	40	1.50	139.86	S	6"	150	5.7	9.18	L	6"	150	5.7	9.18	L
2"	50	1.90	81.65	S	8"	200	7.0	5.21	L	8"	200	7.0	5.21	L
2-½"	65	2.30	54.43	S	10"	250	9.5	3.43	L	10"	250	9.5	3.43	L
3"	80	2.90	34.96	S	12"	300	11.3	2.45	L	12"	300	11.3	2.45	L
4"	100	3.83	19.80	S	14"	350	12.4	1.77	L	14"	350	12.4	1.77	L
					16"	400	15.1	1.36	L	16"	400	15.1	1.36	L
										20"	500	19.0	0.86	L
										24"	600	21.0	0.60	L

Installation Information

Very Important

- Lubricate O-rings with a Viscous Lubricant Compatible with the Materials of Construction.
- Using an Alternating | Twisting Motion Carefully Lower the Sensor into the Fitting. | Do Not Force | Fig 5
- Ensure Tab | Notch are Parallel to Flow Direction | Fig-2

Hand Tighten the Sensor Cap. **DO NOT** use any tools on the sensor cap or the cap threads or fitting threads may be damaged, See Fig-3

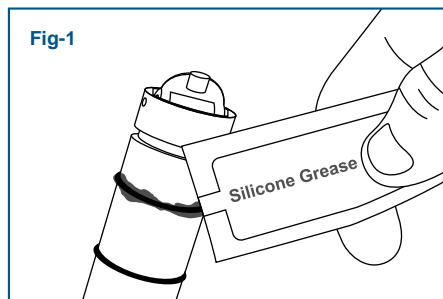

Ensure Silicone Grease (Supplied) is Applied Prior to Insertion

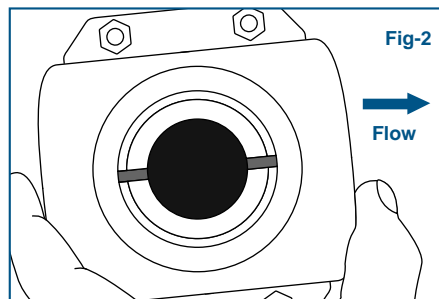

Ensure Location Tabs Are Parallel to Direction of Flow

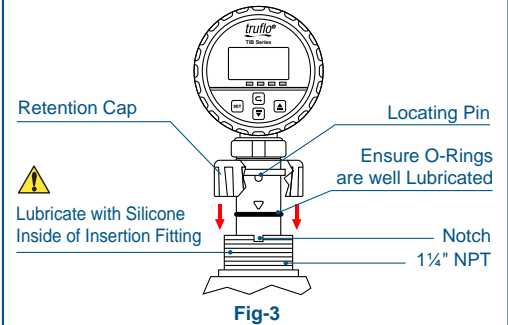

Fig-3

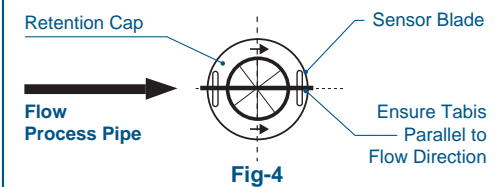

Fig-4

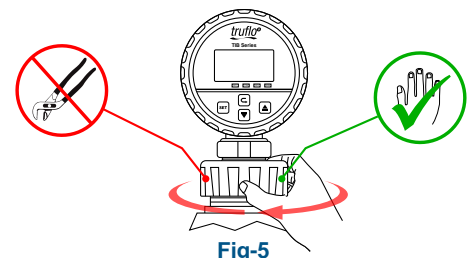
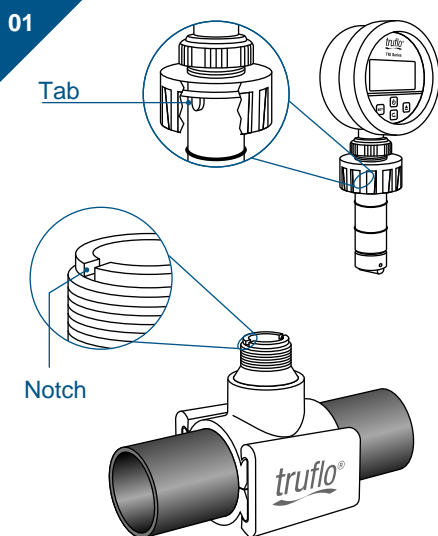
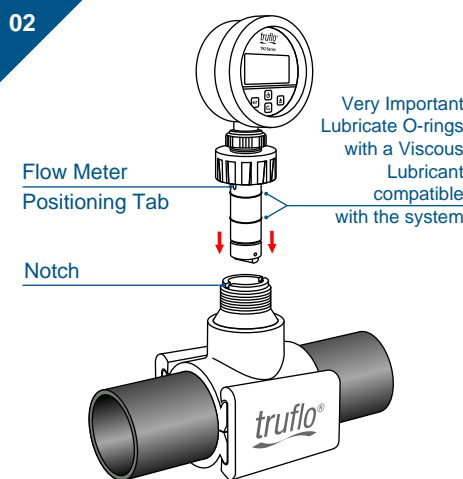

Fig-5

Sensor Installation



Flow Meter Positioning Tab and Clamp Saddle Notch



Engage one Thread of the Sensor Cap then turn the Sensor until the Alignment Tab is Seated in the Fitting Notch, Ensure Tab is Parallel to Flow Direction.

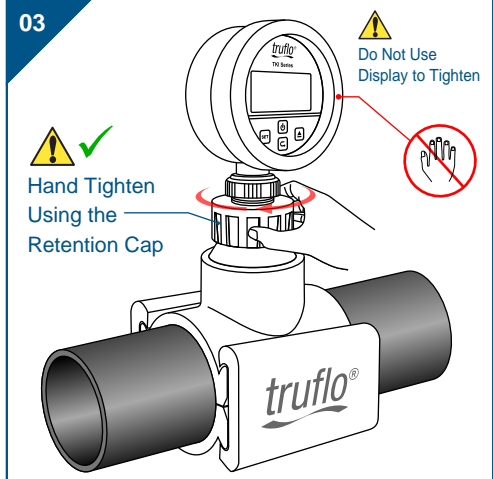

- Hand Tighten the Sensor Cap.
- **DO NOT** use any tools, Threads may be Damaged.
- Ensure Meter is Firmly in Place.

Correction Sensor Position

TI Series Flow Meters measure liquid media only. There should be no air bubbles and the pipe must always remain full. To ensure accurate flow measurement the placement of the flow meters needs to be adhered. This requires a straight run pipe with a minimum number of pipe diameters distance upstream and downstream of the flow sensor.

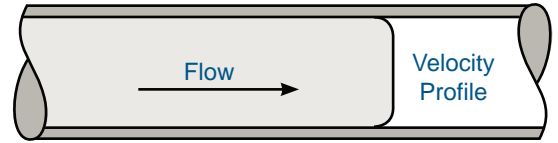

Developed Turbulent Flow

Flange

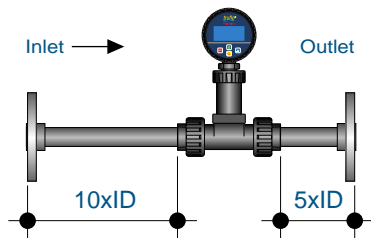

2x 90 Elbow

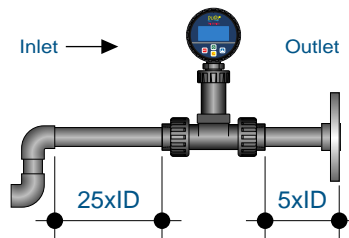

Reducer

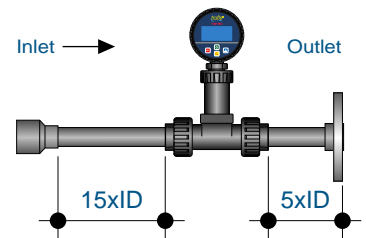

90 Elbow Downward flow

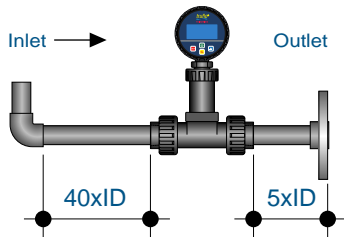

90 Elbow Downward flow Upward

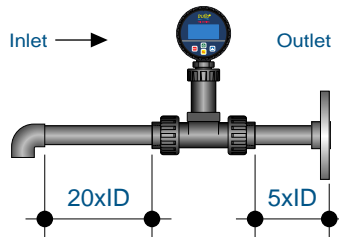

Ball Valve

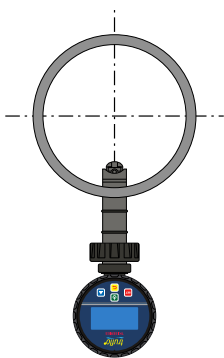
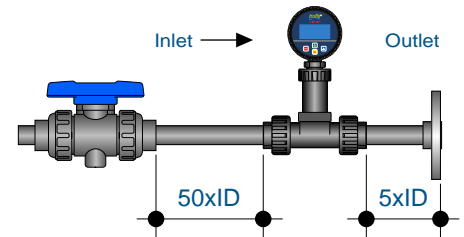

Good if NO Sediment Present

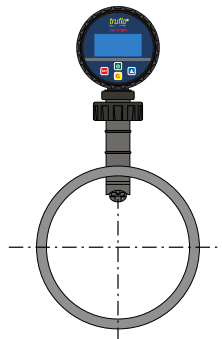

Good if NO Air Bubbles Present

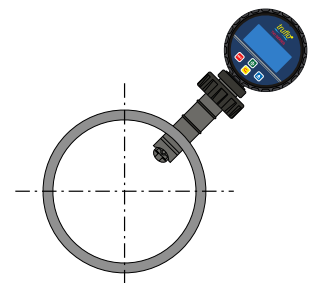

Preferred Installation if Sediment* or Air Bubbles may be Present

* Maximum % Solids: 10% with particle size not exceeding 0.5 mm cross section or length.

Battery Replacement V Series

01

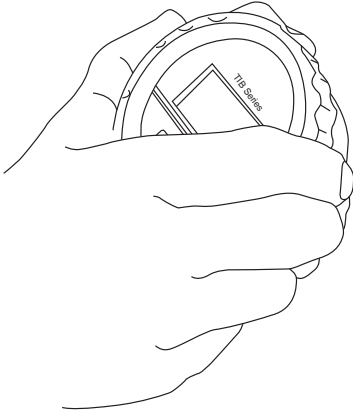

Remove Polycarbonate Lid

02

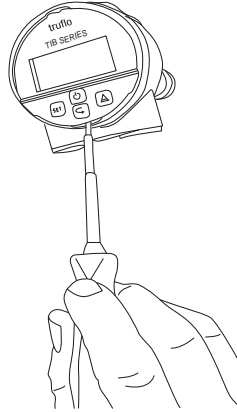

Insert Screw Driver into Slot

03

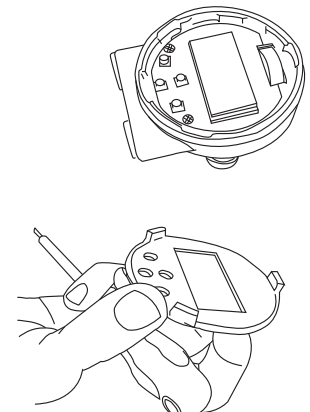

Remove Cover

04

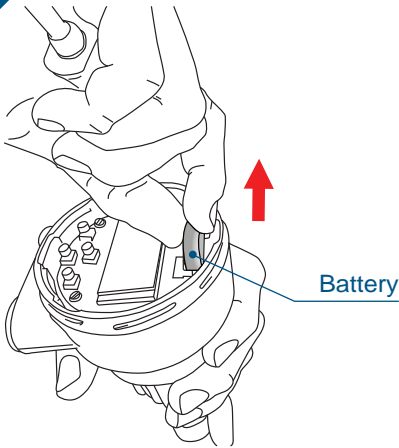

Remove 1st Battery

05

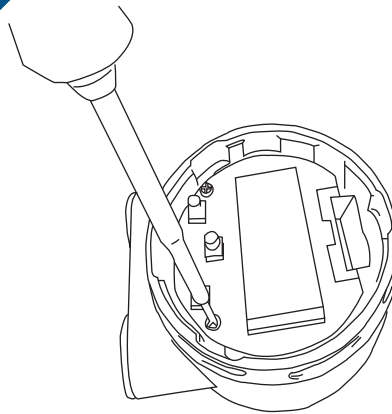

Remove Screws

06

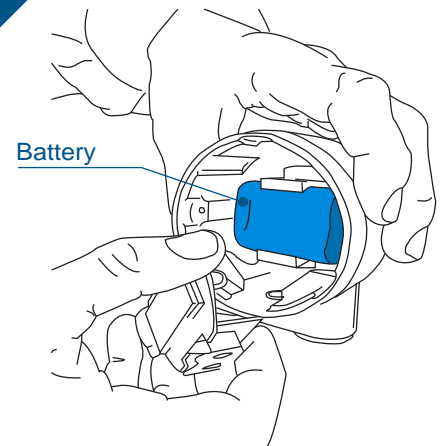

Carefully Remove Display Module

07

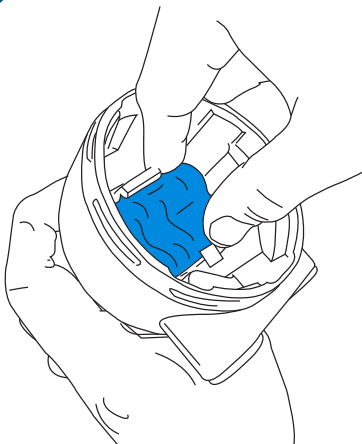

Remove Battery Pack

08

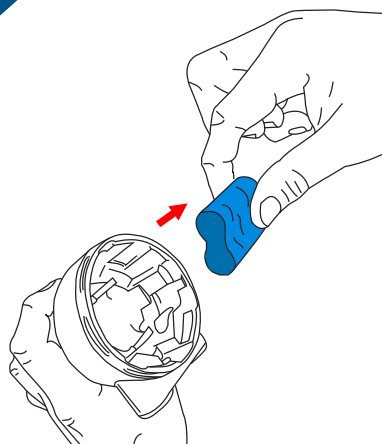

Replace Battery Pack

09

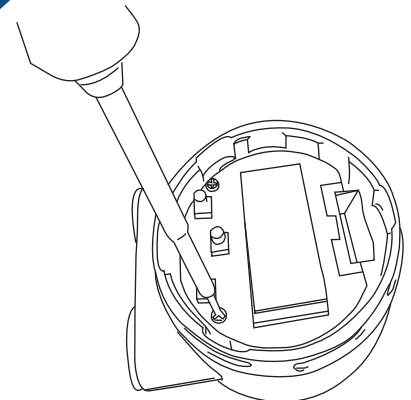

Reassemble

Battery Replacement H Series

01

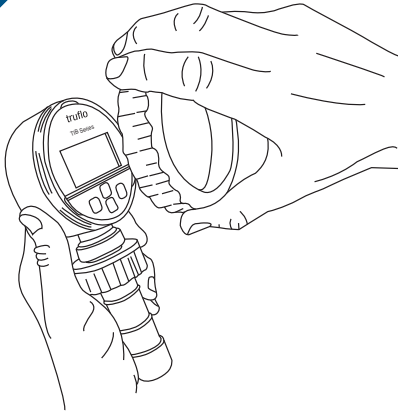

Remove Polycarbonate Lid

02

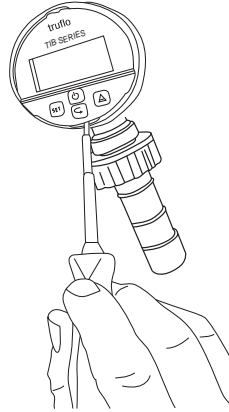

Insert Screw Driver into Slot

03

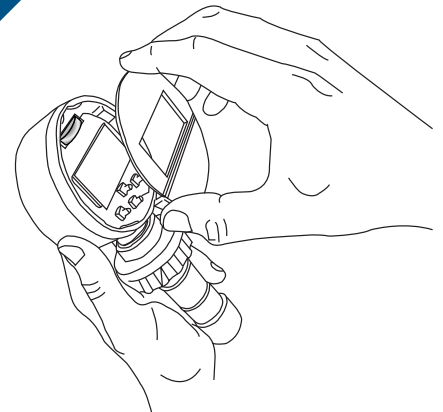

Remove Cover

04

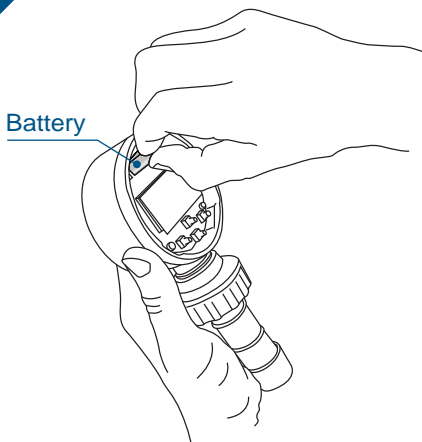

Remove 1st Battery

05

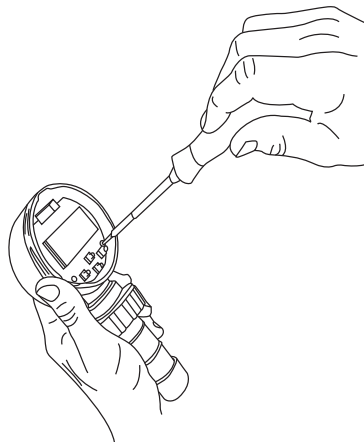

Remove Screws

06

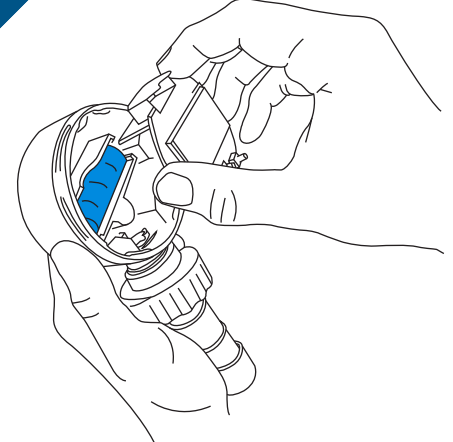

Carefully Remove Display Module

07

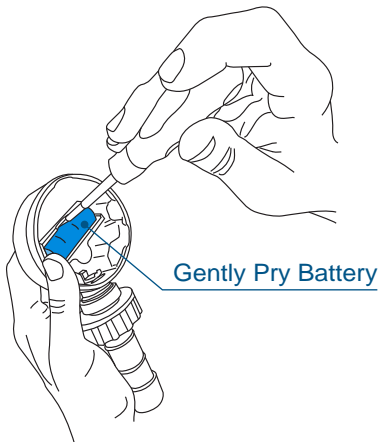

Remove Battery Pack

08

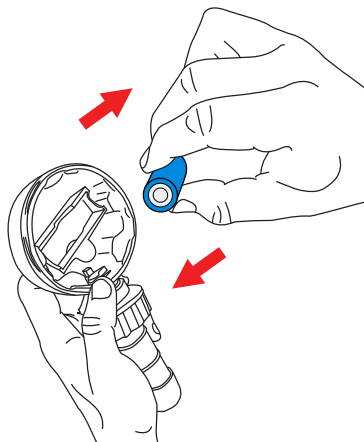

Replace Battery Pack

09

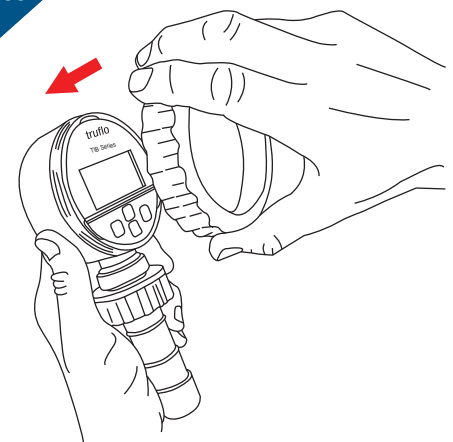

Reassemble

Rotor Pin | Paddle Replacement

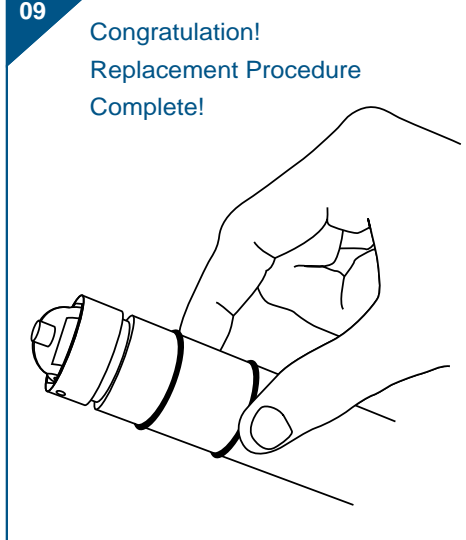
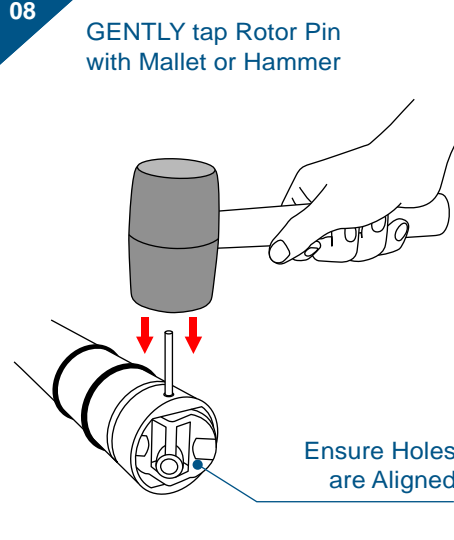
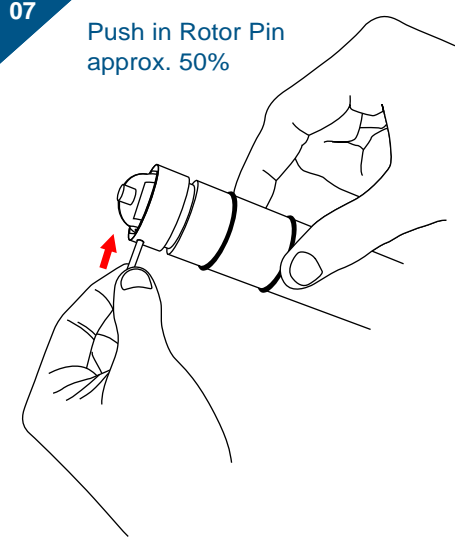
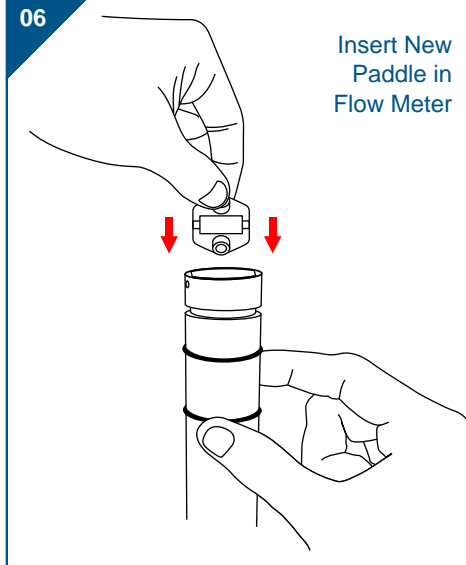
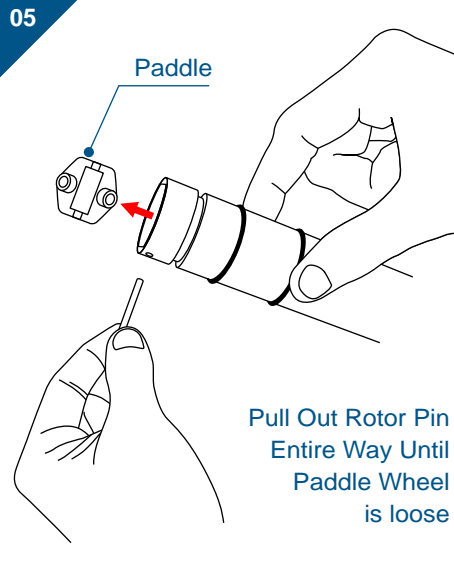
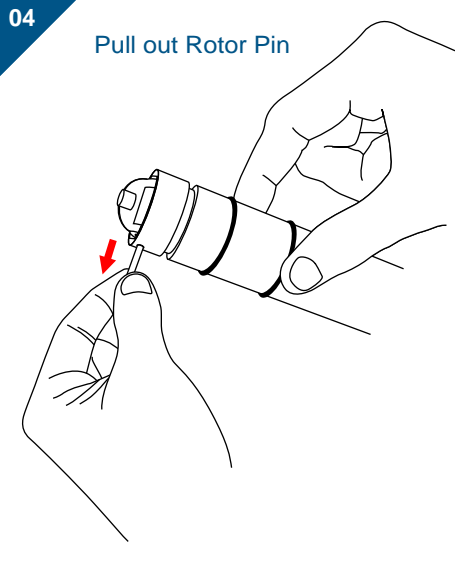
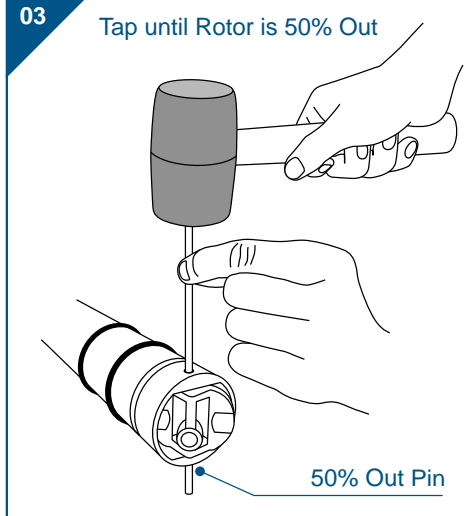
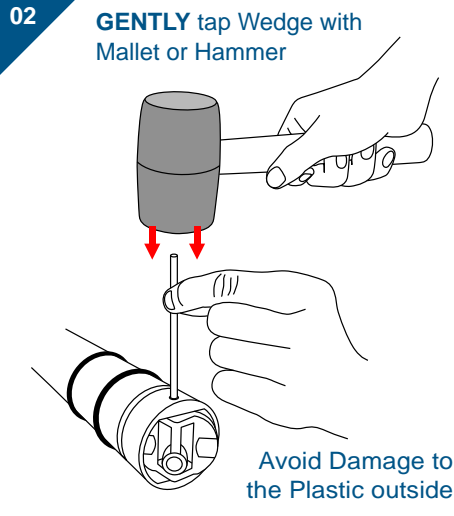
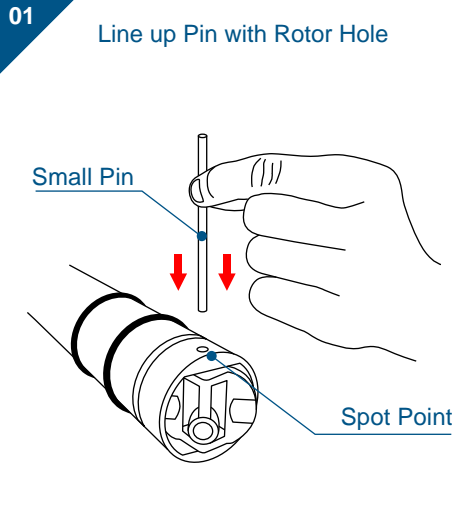

Dimensions

V Series

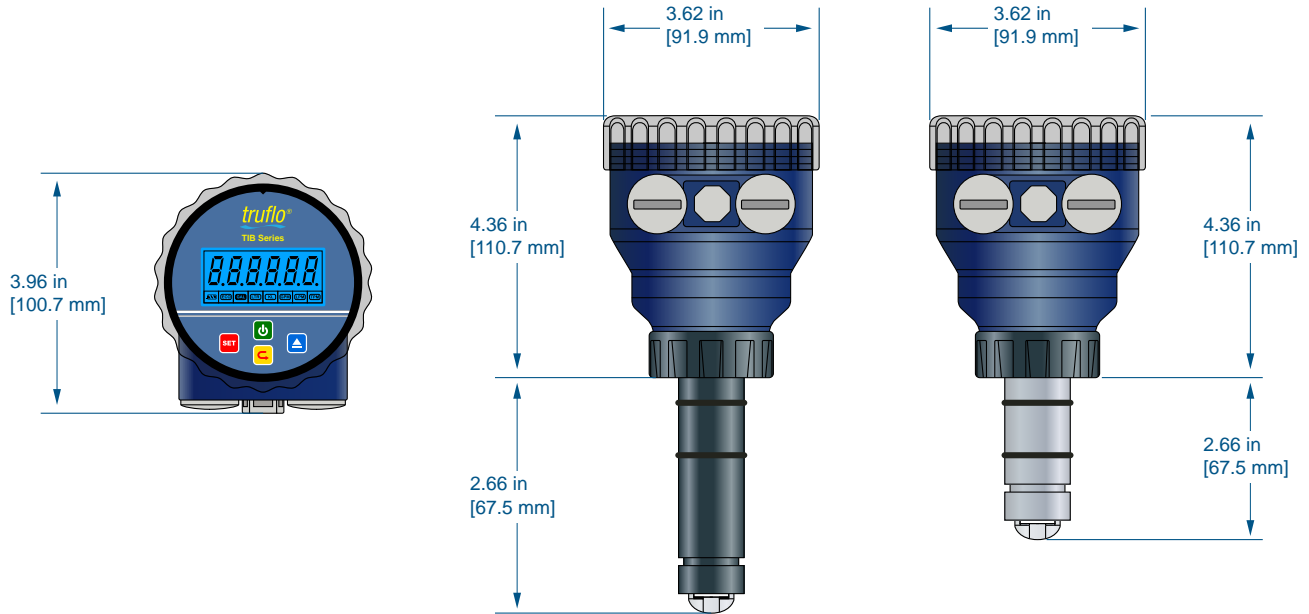

H Series



Warranty, Returns and Limitations

Warranty

Icon Process Controls Ltd warrants to the original purchaser of its products that such products will be free from defects in material and workmanship under normal use and service in accordance with instructions furnished by Icon Process Controls Ltd for a period of one year from the date of sale of such products. **Icon Process Controls Ltd** obligation under this warranty is solely and exclusively limited to the repair or replacement, at **Icon Process Controls Ltd** option, of the products or components, which **Icon Process Controls Ltd** examination determines to its satisfaction to be defective in material or workmanship within the warranty period. Icon Process Controls Ltd must be notified pursuant to the instructions below of any claim under this warranty within thirty (30) days of any claimed lack of conformity of the product. Any product repaired under this warranty will be warranted only for the remainder of the original warranty period. Any product provided as a replacement under this warranty will be warranted for the one year from the date of replacement.

Returns

Products cannot be returned to **Icon Process Controls Ltd** without prior authorization. To return a product that is thought to be defective, go to www.iconprocon.com, and submit a customer return (MRA) request form and follow the instructions therein. All warranty and non-warranty product returns to **Icon Process Controls Ltd** must be shipped prepaid and insured. **Icon Process Controls Ltd** will not be responsible for any products lost or damaged in shipment.

Limitations

This warranty does not apply to products which: 1) are beyond the warranty period or are products for which the original purchaser does not follow the warranty procedures outlined above; 2) have been subjected to electrical, mechanical or chemical damage due to improper, accidental or negligent use; 3) have been modified or altered; 4) anyone other than service personnel authorized by Icon Process Controls Ltd have attempted to repair; 5) have been involved in accidents or natural disasters; or 6) are damaged during return shipment to **Icon Process Controls Ltd** reserves the right to unilaterally waive this warranty and dispose of any product returned to **Icon Process Controls Ltd** where: 1) there is evidence of a potentially hazardous material present with the product; or 2) the product has remained unclaimed at Icon Process Controls Ltd for more than 30 days after Icon Process Controls Ltd has dutifully requested disposition. This warranty contains the sole express warranty made by **Icon Process Controls Ltd** in connection with its products. **ALL IMPLIED WARRANTIES, INCLUDING WITHOUT LIMITATION, THE WARRANTIES OF MERCHANTABILITY AND FITNESS FOR A PARTICULAR PURPOSE, ARE EXPRESSLY DISCLAIMED.** The remedies of repair or replacement as stated above are the exclusive remedies for the breach of this warranty. **IN NO EVENT SHALL Icon Process Controls Ltd BE LIABLE FOR ANY INCIDENTAL OR CONSEQUENTIAL DAMAGES OF ANY KIND INCLUDING PERSONAL OR REAL PROPERTY OR FOR INJURY TO ANY PERSON. THIS WARRANTY CONSTITUTES THE FINAL, COMPLETE AND EXCLUSIVE STATEMENT OF WARRANTY TERMS AND NO PERSON IS AUTHORIZED TO MAKE ANY OTHER WARRANTIES OR REPRESENTATIONS ON BEHALF OF Icon Process Controls Ltd.** This warranty will be interpreted pursuant to the laws of the province of Ontario, Canada.

If any portion of this warranty is held to be invalid or unenforceable for any reason, such finding will not invalidate any other provision of this warranty

For additional product documentation and technical support visit www.iconprocon.com | e-mail: sales@iconprocon.com support@iconprocon.com | Ph: 905.469.9283



Corrosion-Free
Instrumentation Equipment

CORROSION

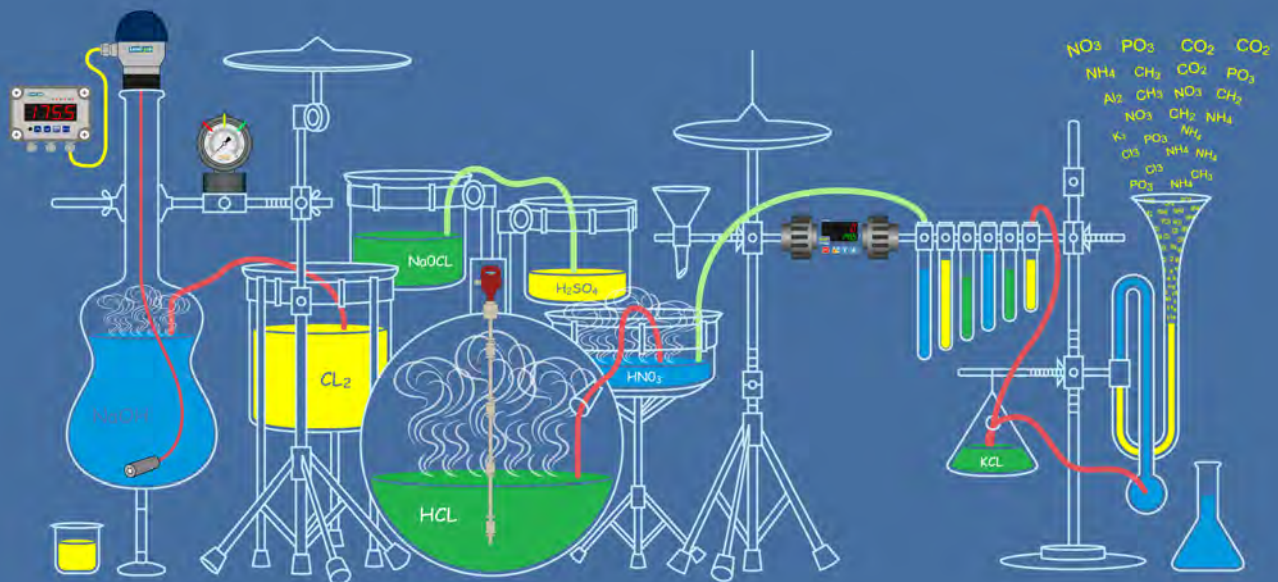

We Measure & Control
All Kinds of Corrosive Liquid S#*o%

'Industry's Most Extensive Line of
Corrosion-Free Instrumentation' Equipment'



Corrosion-Free
Instrumentation Equipment